



INSTALLATION INSTRUCTIONS

PHANTOM

Model XJ-835

Passive Infrared Motion Sensor

Range 35' x 50'  
(11 m x 15 m)

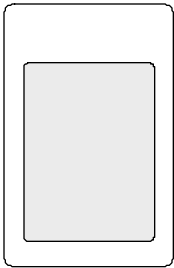

The XJ-835 flush-mount passive infrared motion sensor from IntelliSense provides reliable detection coverage at an affordable price.

The XJ-835 features a dense 35' x 50' pattern, RF immunity, and a low 20 mA current draw. In addition, an adjustable printed circuit board (PCB) makes it possible to adjust the range without relocating the sensor.

This compact, attractive unit is easy to install and maintain. A mounting template is included with the XJ-835 to simplify installation.

FEATURES

- 35' x 50' range
- Dual element PIR
- Dense detection pattern
- Pet-alley mask included
- Low 20 mA current draw at 12 VDC
- 9 - 14 VDC operation
- Form A alarm relay
- RF immunity
- Selectable PIR sensitivity
- Flush-mount installation
- Mirrored optics
- Built-in range adjustment
- Electronic circuit protection

APPLICATIONS

The XJ-835 is ideal for office and residential applications.

MOUNTING LOCATION

The XJ-835 is designed for use indoors. Make sure the sensor has a clear line of sight to the protected area. Infrared energy cannot penetrate solid objects. If the XJ-835 is blocked, it will not alarm.

Aim the XJ-835 toward the interior of the room, away from windows and heating/cooling sources.

A mounting template is provided for easy installation. Trace the template on the mounting surface, then cut and drill the holes. Follow the instructions in the Mounting Procedure section to mount the sensor.

The unit can also be installed in a single-gang electrical box. Follow the installation procedure described in the Mounting Procedure section.

MOUNTING PROCEDURE

To mount the unit:

1. Remove the front housing from the unit by depressing the latch through the slot in the bottom of the XJ-835, while separating the front and rear housings.

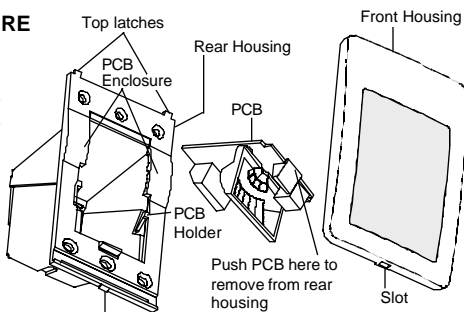

Figure 1 XJ-835 Assembly

MOUNTING PROCEDURE (Continued)

2. Remove the printed circuit board (PCB) by pushing the board in and down (at the same time). When the board is clear of the enclosure, gently pull it from the housing. Refer to Figure 1.
3. Secure the rear housing to the desired location with either two or four #6 slotted countersunk flathead screws. (Make sure the rear housing is mounted upright as shown in Figure 2.)
4. Wire the unit (refer to the Wiring section), and return the PCB to the rear housing.
5. Place the two rectangular labels (provided) over the mounting holes as shown in Figure 2.
6. To replace the front housing: place the inside front housing slots over the top latches of the rear housing and snap the housings together. (Refer to Figure 2.)

WIRING

Terminal strip TB1 is located at the back edge of the PCB.

The XJ-835 rear housing features a convenient PCB holder for wiring. Remove the PCB from the rear housing and slide it into the PCB holder (refer to Figure 2).

Wire the XJ-835 as shown in Figure 3 (use 22 to 14 AWG).

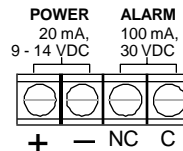
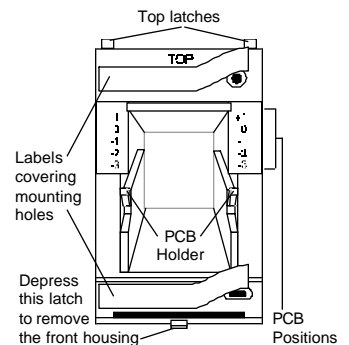

Figure 3 Wiring

Figure 2 Rear Housing



RANGE ADJUSTMENT

The XJ-835 housing is designed for easy PCB adjustment. This allows for detection range adjustment without relocating the sensor.

To adjust the range:

- Refer to the XJ-835 Range Chart on the right.
- At the left side of the chart, find the desired mounting height.
- On the top of the chart, find the required PCB position.
- The square where PCB position and mounting height intersect is the pattern distance.
- Press the PCB in and move it up or down until it "clicks" into the desired PCB position. (Refer to Figure 2.)
- Walk-test the sensor.

XJ-835 Range Chart

MTG HEIGHT	PCB POSITION				
	+1	0	-1	-2	-3
3' 4"	35'	*	*	*	*
6'	*	35'	30'	25'	15'
8'	*	*	35'	30'	20'
10'	*	*	*	35'	25'

\*PCB Positions not recommended.

PET-ALLEY MASK

The pet-alley mask blocks lower zones to exclude small pets from the field of view.

To install the pet-alley mask:

1. Remove the PCB from the rear housing.
2. Install the masking material (provided) over the two lower and four intermediate PIR mirror segments. (See Figure 4.)
3. Return the PCB to the rear housing and walk-test the unit.

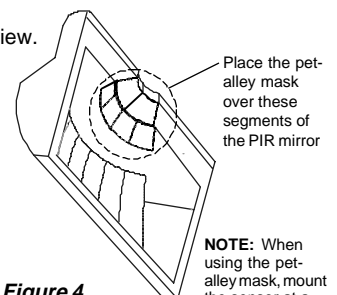

NOTE: When using the pet-alley mask, orient the sensor at a height of 3' 4" and set the PCB at position +1.

Figure 4 XJ-835 PIR MIRROR

## PIR SENSITIVITY

The XJ-835 is equipped with a dip switch for selecting PIR sensitivity. Refer to the chart below to determine which sensitivity level is best suited for your application.

**Figure 5** Setting the PIR Sensitivity

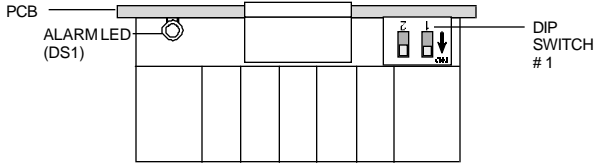

SENSITIVITY	DIP SWITCH #1
<b>LOW</b> (Pulse count 3)	OFF
<b>HIGH</b> (Pulse count 2)	ON

## WALK-TEST

Apply power to the unit and let it warm up for at least three minutes. Begin walk-testing when the alarm LED (DS1) goes out.

Walk across the protected area at the ranges to be covered. Two to four normal steps across the pattern should make the alarm LED light. Wait for the alarm LED to go out, then continue walk-testing. When there is no motion in the protected area, the alarm LED should be off.

**Important:** The XJ-835 should be tested at least **once each year** to ensure proper operation.

## ALARM LED DISABLE

To disable the alarm LED (DS1) after walk-testing the sensor, move DIP Switch #2 to the OFF position. See Figure 5.

## SPECIFICATIONS

### Range:

35' x 50'  
(11 m x 15 m)

### Alarm relay:

Form A (normally closed)  
100 mA, 30 VDC

### Power requirements:

9 - 14 VDC  
20 mA, 12 VDC

### RF immunity:

30 V/m, all mobile bands  
10 - 1000 MHz

### White light immunity:

up to 20,000 candlepower at 10'  
(3 m)

### Operating temperature:

32° to 120° F (0° to 49° C)

### PIR fields of view:

7 long range zones  
4 intermediate  
2 lower

### PIR sensitivity:

DIP switch selectable pulse count;  
pulse count 2 (high) or pulse  
count 3 (low)

### Dimensions:

4.5" high x 2.9" wide x 2.5" deep  
(11.4 cm x 7.4 cm x 6.4 cm)

### Weight:

3 oz (84 g)  
Packaged Product is 6 oz (170 g)

### Approvals/Listings:

UL listed

**Important:** The XJ-835 must be connected to a UL listed power supply or UL listed control panel capable of providing a **minimum of four hours** of standby power.

## PROTECTION PATTERNS

TOP VIEW  
Wide Angle Pattern

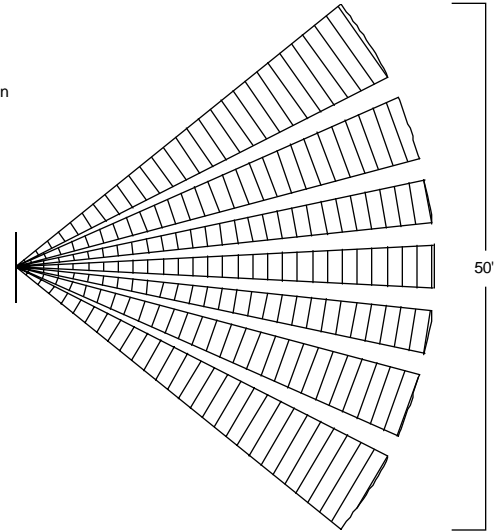

SIDE VIEW  
Wide Angle Pattern

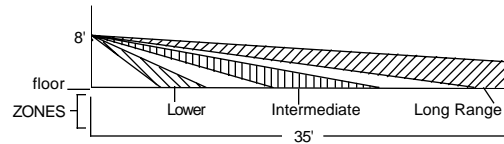

TOP VIEW  
Pet-Alley Pattern

The TOP VIEW Pet-Alley Pattern is the same as the TOP VIEW Wide Angle Pattern.

SIDE VIEW  
Pet-Alley Pattern

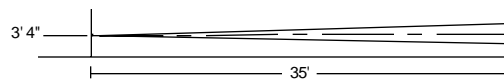

## LIMITED WARRANTY

Seller warrants its products to be in accordance with its own plans and specifications and to be free from defects in materials and workmanship under normal use and service for **18 months** from the date stamp control on the product; or for products not having an IntelliSense Systems date stamp, for **12 months** from the date of original purchase, unless the installation instructions or catalogue sets forth a shorter period, in which case the shorter period shall apply.

Seller's obligation shall be limited to repairing or replacing, at its option, free of charge for materials or labor, any part which is proved not in compliance with Seller's specifications or proves defective in materials or workmanship under normal use and service. This warranty is void if the product is altered or improperly repaired or serviced by anyone other than an authorized IntelliSense factory service center. Contact your local IntelliSense distributor for the service center location nearest you.

THERE ARE NO WARRANTIES, EXPRESS OR IMPLIED, OF MERCHANTABILITY, OR FITNESS FOR A PARTICULAR PURPOSE OR OTHERWISE, WHICH EXTEND BEYOND THE DESCRIPTION ON THE FACE HEREOF. In no case shall Seller be liable to anyone for any consequential or incidental damages for breach of this or any other warranty, express or implied, or upon any other basis of liability whatsoever, even if the loss or damage is caused by Seller's own negligence or fault.

Seller does not represent that its product may not be compromised or circumvented; that the product will prevent any personal injury or property loss by burglary, robbery, fire, or otherwise; or that the product will in all cases provide adequate warning or protection. Buyer understands that a properly installed and maintained alarm system may only reduce the risk of burglary, robbery, or fire without warning, but it is not insurance or guarantee that such will not occur or that there will be no personal injury or property loss as a result. CONSEQUENTLY, SELLER SHALL HAVE NO LIABILITY FOR ANY PERSONAL INJURY, PROPERTY DAMAGE, OR OTHER LOSS BASED ON A CLAIM THAT THE PRODUCT FAILED TO GIVE WARNING. However, if Seller be held liable, whether directly or indirectly, for any loss or damage arising under this Limited Warranty or otherwise, regardless of cause or origin, Seller's maximum liability shall not in any case exceed the purchase price of the product, which shall be fixed as liquidated damages and not as a penalty, and shall be the complete and exclusive remedy against Seller.

This warranty replaces all previous warranties and is the only warranty made by IntelliSense on this product. No increase or alteration, written or verbal, of the obligation of this warranty is authorized.